

Student Name _____

Teacher Name _____

School _____

System _____

BIOLOGY I



Practice Test

Tennessee End of Course Assessment

**Biology I
Form 1**

PEARSON

Developed and published under contract with State of Tennessee Department of Education by the Educational Measurement group of Pearson, a business of NCS Pearson, Inc., 2510 North Dodge Street, Iowa City, Iowa 52245. Copyright © 2012 by State of Tennessee Department of Education. All rights reserved. No part of this publication may be reproduced or distributed in any form or by any means, or stored in a database or retrieval system, without the prior written permission of State of Tennessee Department of Education.

Contents

Introduction to Biology I	4
Content of tests	4
Test development	4
Test administration	4
Tips for Taking the Test.....	5
Preparing for the test.....	5
Before the test	5
During the test.....	5
Answer Sheet for the Practice Test.....	6
Directions for Taking the Practice Test	7
Biology I Practice Test.....	8
Answer Key.....	73
Reporting Categories.....	74

Introduction to Biology I

Content of tests

The testing program titled the *Tennessee End of Course Assessment* was established to meet the Tennessee mandate for end of course assessments in Tennessee secondary schools. These tests measure the Tennessee State Performance Indicators. Subject areas covered by the end of course assessments include Mathematics, Language Arts, History, and Science.

Test development

For the *Tennessee End of Course Assessment*, professional item writers experienced in each of the content areas researched and wrote the items. Professional editors and test developers carefully reviewed all items and test directions for content and accuracy. To provide a large pool of items for final test selection, the test developers created approximately 50% more items as were needed in the final editions of the tests.

After items were field tested, student responses were analyzed. Professional content editors and researchers carefully reviewed items, their data, and test directions for content, suitability, and accuracy before including certain items and test directions in operational tests.

Test administration

Tennessee End of Course Assessments are given to students as they are completing courses that are included in the program. Tests may be given midyear for block schedules or at the end of the school year.

Each test contains 65 multiple-choice questions.

You will have ample time to read and answer each of the questions. The Biology I test has been designed to be administered in one session and is not timed. The first 15 minutes are set aside to complete identifying data on the answer sheet.

Tips for Taking the Test

Preparing for the test

- Take this Practice Test several times
- Review the Tennessee End of Course Item Sampler for Biology I located at http://tennessee.gov/education/assessment/sec_samplers.shtml on the Tennessee Department of Education Web site.
- Become familiar with the correct way to mark answers on the answer sheet. There is a sample answer sheet in this Practice Test.

Before the test

- Get a good night's sleep. To do your best, you need to be rested.

During the test

- Relax. It is normal to be somewhat nervous before the test. Try to relax and not worry.
- Listen. Listen to and read the test directions carefully. Ask for an explanation of the directions if you do not understand them.
- Plan your time. Do not spend too much time on any one question. If a question seems to take too long, skip it and return to it later. First answer all questions that you are sure about.
- Think. If you are not sure how to answer a question, read it again and try your best to answer the question. Rule out answer choices that you know are incorrect and choose from those that remain.

Answer Sheet for the Practice Test

1 (A)(B)(C)(D)	14 (A)(B)(C)(D)	27 (A)(B)(C)(D)	40 (A)(B)(C)(D)	53 (A)(B)(C)(D)
2 (A)(B)(C)(D)	15 (A)(B)(C)(D)	28 (A)(B)(C)(D)	41 (A)(B)(C)(D)	54 (A)(B)(C)(D)
3 (A)(B)(C)(D)	16 (A)(B)(C)(D)	29 (A)(B)(C)(D)	42 (A)(B)(C)(D)	55 (A)(B)(C)(D)
4 (A)(B)(C)(D)	17 (A)(B)(C)(D)	30 (A)(B)(C)(D)	43 (A)(B)(C)(D)	56 (A)(B)(C)(D)
5 (A)(B)(C)(D)	18 (A)(B)(C)(D)	31 (A)(B)(C)(D)	44 (A)(B)(C)(D)	57 (A)(B)(C)(D)
6 (A)(B)(C)(D)	19 (A)(B)(C)(D)	32 (A)(B)(C)(D)	45 (A)(B)(C)(D)	58 (A)(B)(C)(D)
7 (A)(B)(C)(D)	20 (A)(B)(C)(D)	33 (A)(B)(C)(D)	46 (A)(B)(C)(D)	59 (A)(B)(C)(D)
8 (A)(B)(C)(D)	21 (A)(B)(C)(D)	34 (A)(B)(C)(D)	47 (A)(B)(C)(D)	60 (A)(B)(C)(D)
9 (A)(B)(C)(D)	22 (A)(B)(C)(D)	35 (A)(B)(C)(D)	48 (A)(B)(C)(D)	61 (A)(B)(C)(D)
10 (A)(B)(C)(D)	23 (A)(B)(C)(D)	36 (A)(B)(C)(D)	49 (A)(B)(C)(D)	62 (A)(B)(C)(D)
11 (A)(B)(C)(D)	24 (A)(B)(C)(D)	37 (A)(B)(C)(D)	50 (A)(B)(C)(D)	63 (A)(B)(C)(D)
12 (A)(B)(C)(D)	25 (A)(B)(C)(D)	38 (A)(B)(C)(D)	51 (A)(B)(C)(D)	64 (A)(B)(C)(D)
13 (A)(B)(C)(D)	26 (A)(B)(C)(D)	39 (A)(B)(C)(D)	52 (A)(B)(C)(D)	65 (A)(B)(C)(D)

Directions for Taking the Practice Test

In this Practice Test, you will answer various science questions. You may write in the open spaces in this book to work the questions, but remember to fill in the circle on your answer sheet that goes with the answer you choose for each question. Fill in the circle completely and make your mark heavy and dark. If you want to change an answer, erase the mark you made and make a new mark.

You will do the items in this Practice Test by yourself. Remember to read all the directions carefully. When you have finished, you may check for answers.

On your answer sheet, find Number 1. Mark your answers beginning with Number 1.

You may begin. Stop when you have finished the test.

At the end of the Practice Test, make sure that all your marks are heavy and dark and that you have completely erased any marks that you do not want.

Turn to Page 73 and locate the Answer Key. Check your answers and review those items that you marked incorrectly.

1. Why is DNA important for protein synthesis?

- A** DNA is used as a source of amino acids to produce a protein.
- B** RNA molecules build a DNA strand that synthesizes a protein.
- C** DNA interacts with the RNA to add amino acids during protein synthesis.
- D** DNA is used as a template to produce RNA that is translated to a protein.

2. What molecule is produced during both photosynthesis and cellular respiration to power chemical reactions occurring in both of these cellular events?

- A** ATP
- B** carbon dioxide
- C** glucose
- D** water

3. The diagram shows a drawing of a cell.

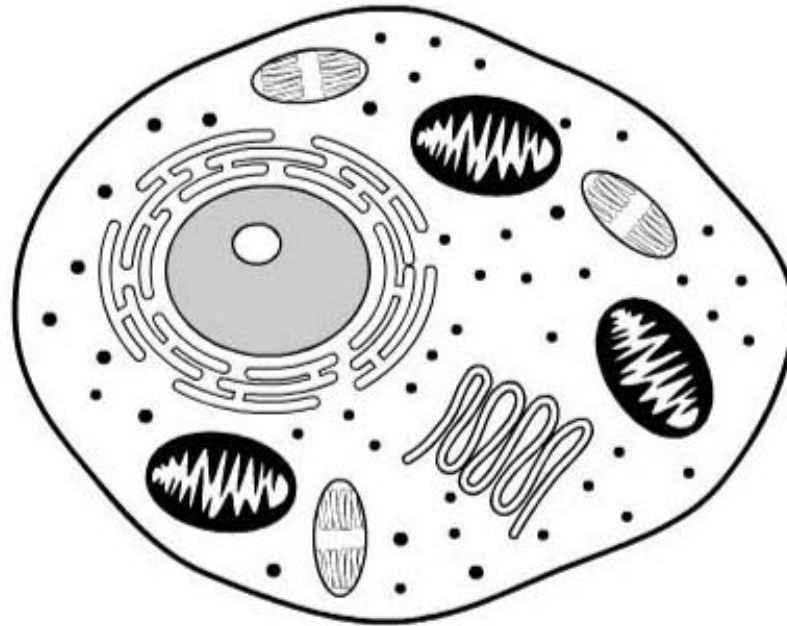

Which cellular component identifies the cell shown as a eukaryotic cell?

- A** nucleus
- B** ribosome
- C** cytoplasm
- D** cell membrane

4. In people, dimples are a dominantly inherited trait. If both parents are heterozygous for the dimple gene, what is the probability that their child will have dimples?

A 25%

B 50%

C 75%

D 100%

5. Tay-Sachs is a disease that occurs when lipids accumulate in cells. This lipid accumulation occurs because of the inability of the cell to break down lipids due to the lack of function of the organelle responsible for intracellular digestion. Which organelle is defective in Tay-Sachs disease?

- A** Golgi apparatus
- B** lysosome
- C** mitochondrion
- D** ribosome

6. A forest fire adds ash minerals to the soil. The thick cover of tree leaves is reduced to scattered bare trunks and stumps. Which response to this ecosystem change is most likely?

- A reduced available sunlight
- B increased populations of predators
- C rapid growth of ground-level plants
- D increased capacity to absorb rainwater

7. Students are planning an investigation to determine the rate at which photosynthesis occurs in plants. After they did research and made observations, they included the following steps in their investigation: writing a conclusion, taking measurements, creating a hypothesis, and interpreting data. Which of these steps should be first in the investigation?

- A** interpreting data
- B** writing a conclusion
- C** creating a hypothesis
- D** taking measurements

8. This is a diagram of part of a DNA molecule:

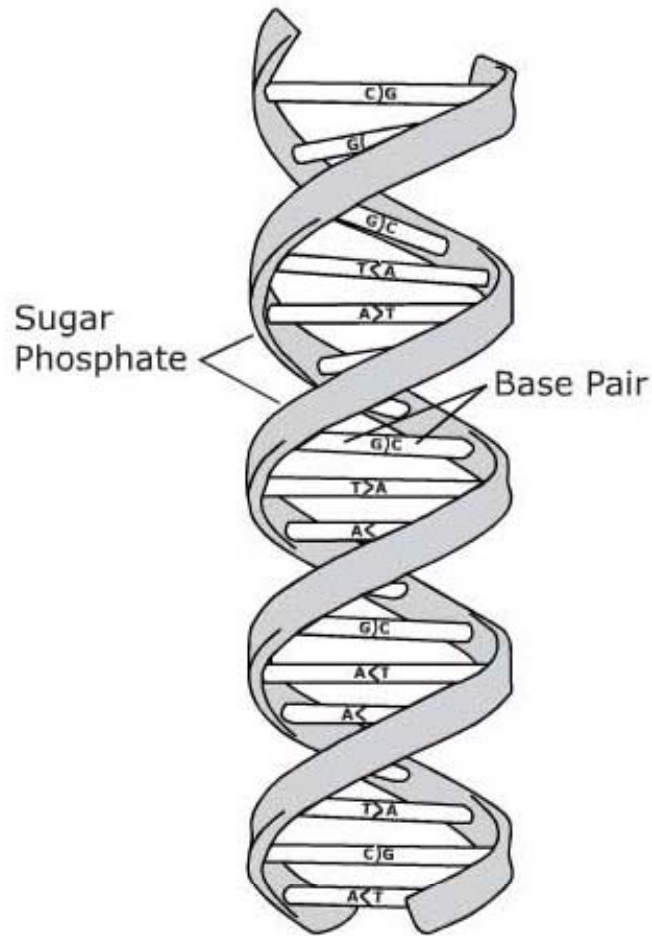

What is the function of the structure labeled "Base Pair"?

- A** storing chemical energy for protein synthesis
- B** storing amino acids used for protein synthesis
- C** storing information used for protein synthesis
- D** storing electrical charge for protein synthesis

9. Cacti have leaves that are modified into spines. Water lilies have large, flat leaves. Why do cacti have leaves shaped differently than the leaves of water lilies?

- A** to store water
- B** to produce food
- C** to provide protection
- D** to conserve carbon dioxide

10. Francesco Redi placed raw meat in two flasks. One flask was sealed while the other flask was open, allowing flies to land on the meat. After a period of time, larvae were observed growing on the meat that was not sealed, but the meat in the sealed flask did not have larvae. Louis Pasteur boiled meat broth in a modified flask that prevented direct exposure to air. After a long period of incubation, no microorganisms were present in the meat broth. Both Francesco Redi and Louis Pasteur concluded that organisms do not directly originate from nonliving matter. How did the research of these two people help disprove the theory of spontaneous generation?

- A** They showed that by covering food, spoilage is prevented.
- B** They showed that by heating food, flies and microbes are unable to reproduce.
- C** They showed that airborne organisms are attracted to solid food instead of food in liquid form.
- D** They showed that airborne organisms are the reason that maggots and microbes appear in food.

11. In a biology lab, students did an experiment to study how the mass of a piece of potato in the shape of a cube changed. They determined the mass of the cube, placed the cube in a 10% salt solution, and measured the mass of the cube again. Which piece of equipment did the students use to measure the mass of the potato cube?

- A** beaker
- B** balance
- C** test tube
- D** metric ruler

12. When iodine was added to a clear unknown solution, the solution's color changed to black. Which molecule is indicated by this change in color?

- A a lipid
- B a protein
- C a complex carbohydrate
- D a simple carbohydrate

13. The diagram represents a pathway of enzyme activity.

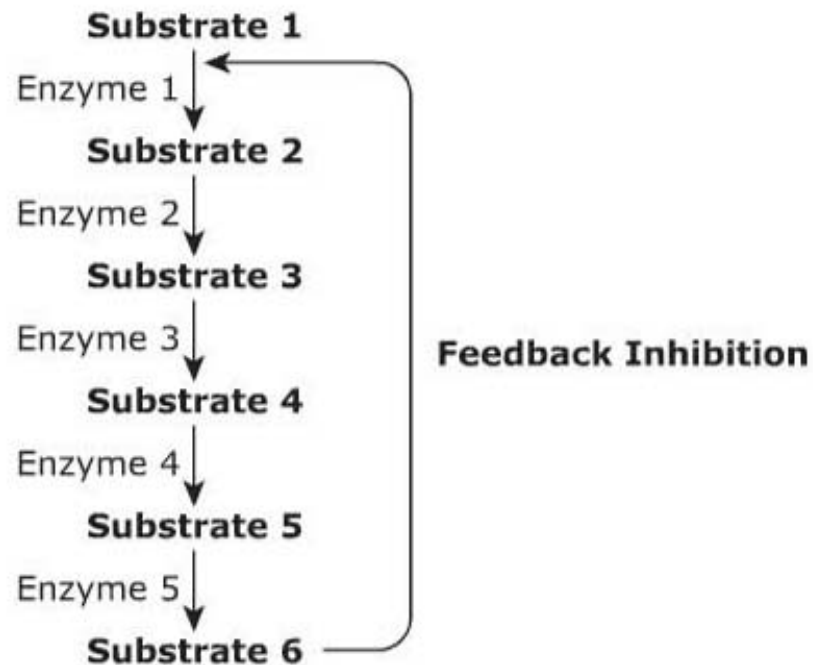

Which statement best describes the enzyme–substrate interaction?

- A** The final product of the reaction regulates enzyme 1 activity.
- B** The final product of the reaction regulates substrate 2 activity.
- C** Different substrates react with different binding sites on one enzyme.
- D** Different enzymes react with the same substrate to produce a final product.

14.

This graph illustrates the relationship between wavelength of light and rate of photosynthesis in a plant.

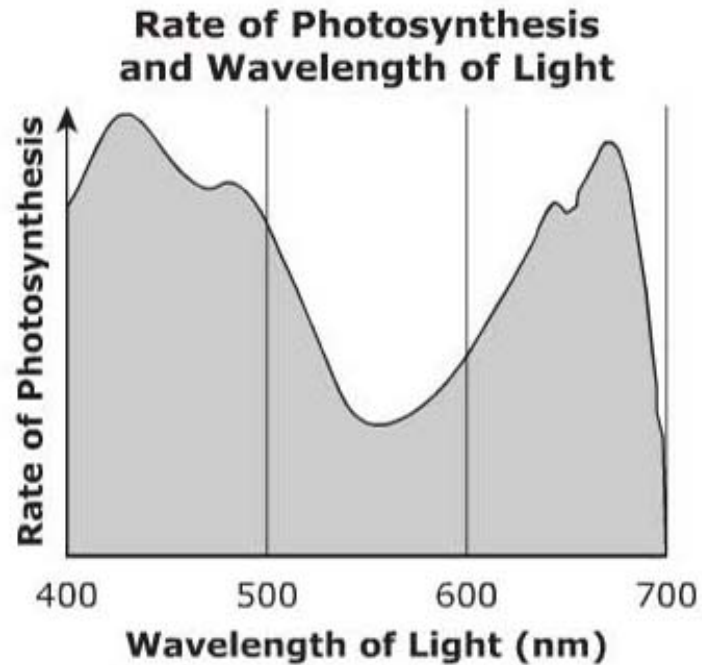

A plant exposed to light with a wavelength of about 430 nm will produce which substance more quickly than a plant of the same size and species exposed to equally bright light with a wavelength of about 550 nm?

- A carbon dioxide
- B nitrogen
- C sugars
- D lipids

15. The food web below shows several species in the Everglades ecosystem.

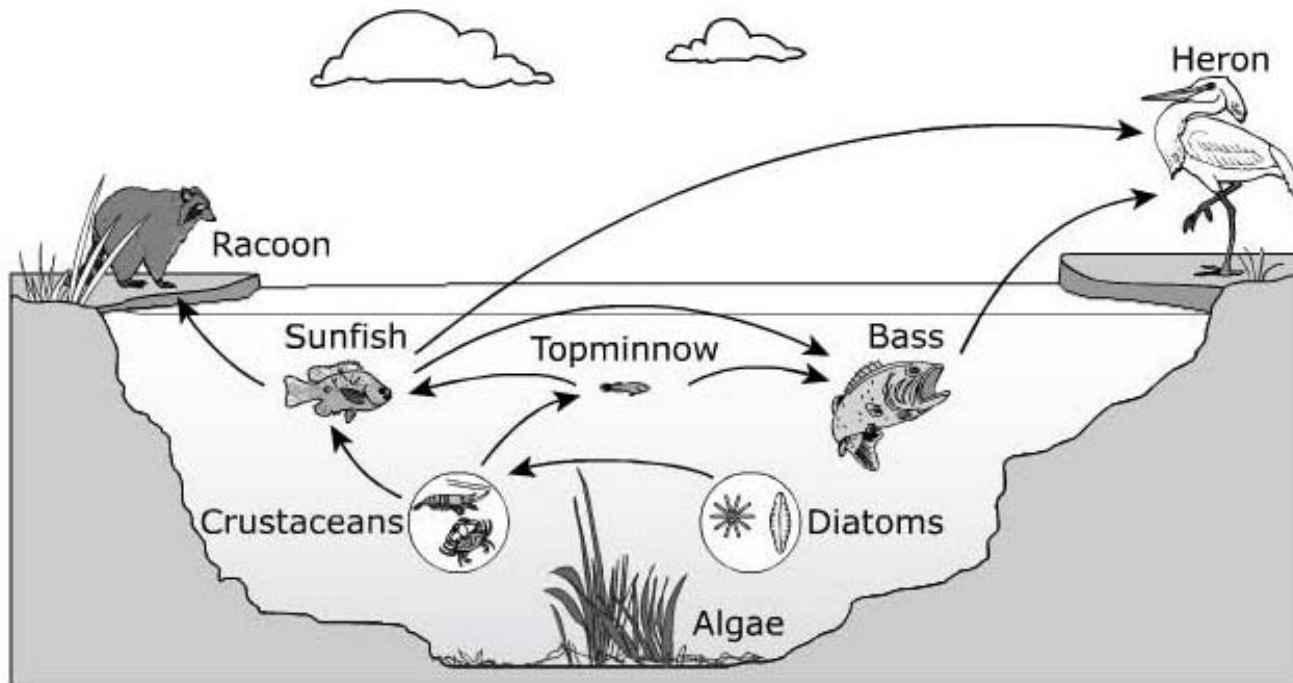

Which organism provides energy input directly to the bass in this food web?

- A** heron
- B** diatoms
- C** sunfish
- D** crustaceans

16. Which macromolecule is the main component of cell membranes?

A carbohydrate

B lipid

C nucleic acid

D protein

- 17.** A student measures the mass of each of six potato cores and places one core in each of the unknown solutions. After a period of time, the student removes the potato cores and measures the mass of each one. The results are shown in the table.

Solution	Potato Core Mass
1	Increase
2	Decrease
3	No Change
4	No Change
5	Decrease
6	Increase

Which statement best describes a conclusion the student can make about the results?

- A** Solution 1 is hypertonic because water flowed out of the cells of the potato.
- B** Solution 6 is hypertonic because water flowed out of the cells of the potato.
- C** Solutions 2 and 5 are hypotonic because water entered the cells of the potatoes.
- D** Solutions 3 and 4 are isotonic because water flowed equally in and out of the cells of the potatoes.

- 18.** The figure is a pedigree showing the occurrence of a genetic trait in several generations of a family.

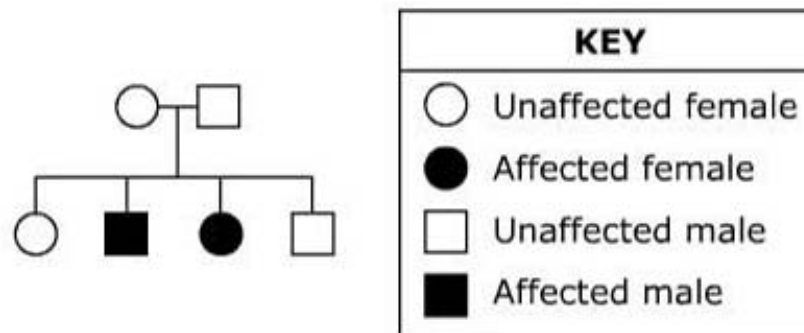

Which type of inheritance is illustrated in the pedigree?

- A** autosomal dominant
- B** autosomal recessive
- C** X-linked dominant
- D** X-linked recessive

- 19.** The antelope jackrabbit lives in a desert environment with limited rainfall, sparse vegetation, and varying temperatures. When avoiding predators it can reach speeds of up to 45 miles per hour. The jackrabbit can control blood flow to its large ears, allowing it to adapt to changing environmental stimuli.

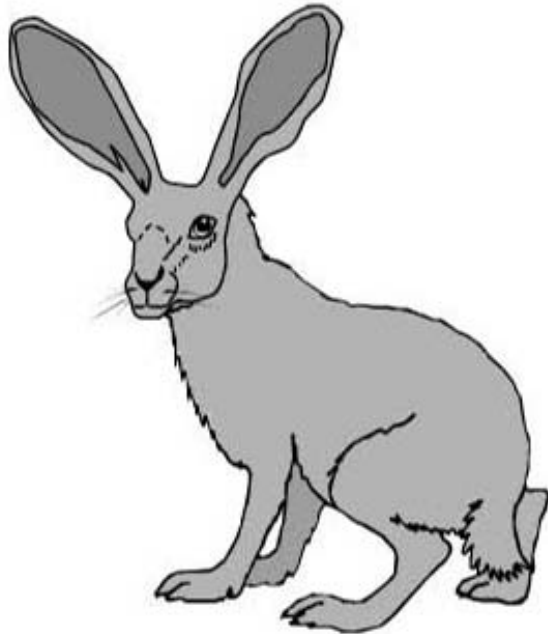

Which statement **best** explains why a jackrabbit's ability to control blood flow to its ears is important for surviving in a desert environment?

- A** Controlling blood flow enables the jackrabbit to absorb water vapor in the air.
- B** Controlling blood flow allows the jackrabbit to release carbon dioxide when running.
- C** Controlling blood flow allows the jackrabbit to adjust its sensitivity to noise.
- D** Controlling blood flow allows the jackrabbit to regulate body temperature.

20. In all organisms, substances are transported in and out of cells. What is required for the process of active transport but not for the process of passive transport?

- A** concentration gradient
- B** carrier proteins
- C** energy
- D** ions

21. The red wolf is an endangered species in the southeastern part of the United States. These animals are carnivores and eat deer, rodents, and small mammals. Which change in the environment would most likely threaten the population of red wolves?

- A** release of a large number of deer into the wolf range
- B** extensive loss of habitat due to deforestation
- C** an abnormally wet summer
- D** an abnormally warm fall

22. A student is assigned to determine whether a particular microbe is eukaryotic or prokaryotic. Which procedure is best suited to completing this assignment?

- A measuring the amount of oxygen released using a sensor
- B examining the DNA sequence of the microbes
- C measuring the microbes using a micrometer
- D examining the microbes under a microscope

23. Humans who are positive for the Rh blood type have an antigen on their red blood cells. Humans who do not have the antigen on their red blood cells are Rh negative. The Rh blood type is dominant to Rh negative. What is the probability that a child will be Rh negative if the parents are heterozygous for Rh?

A 25%

B 50%

C 75%

D 100%

24. Protease is an enzyme involved in the digestion of proteins. How does protease interact with protein molecules?

- A** Protease manufactures new proteins.
- B** Protease blocks the activity of proteins.
- C** Protease facilitates the breakdown of proteins.
- D** Protease bonds with protein to form a new compound.

25. Genetic variation in populations arises through a number of biological processes. Which statement best describes the cause of this variation?

- A** Meiosis produces gametes that are identical to each other.
- B** Random fertilization of an egg cell by a sperm cell increases variation.
- C** Acquired characteristics caused by environmental pressures are passed from parents to offspring.
- D** Meiosis produces gametes with a genetic makeup identical to the genetic makeup of the parent.

26. The food web shows organisms that live in a wetland ecosystem.

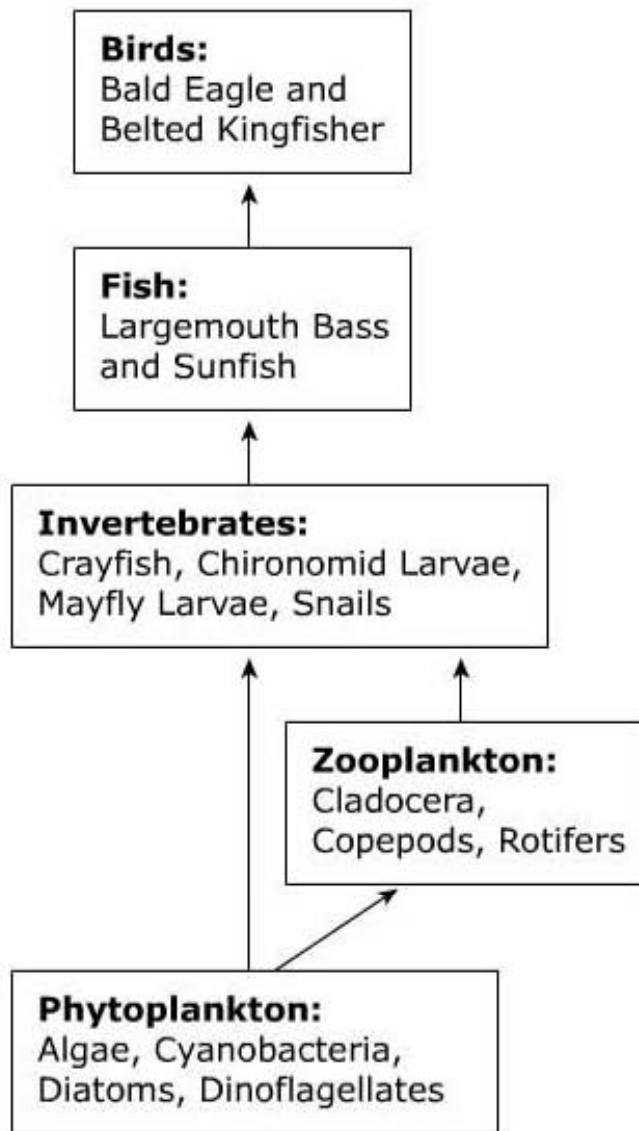

Which trophic level(s) will most likely be negatively affected by a decrease in the crayfish population?

- A producers
- B primary consumers
- C producers and primary consumers
- D secondary and tertiary consumers

27. Petroleum fuel is used for heating, industry, and transportation. What direct effect does the combustion of petroleum have on the environment?

- A** reduced air quality
- B** reduced food supply
- C** reduced water supply
- D** reduced mineral resource quality

28. The diagram shows a forest food web.

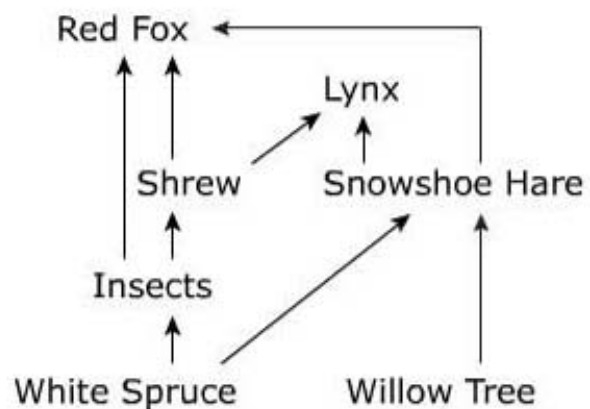

In this diagram, energy flows to which organism from multiple trophic levels?

- A** shrew
- B** red fox
- C** willow tree
- D** snowshoe hare

29. Which statement best describes the differences between the process of aerobic respiration and fermentation?

- A** Aerobic respiration requires oxygen and produces more ATP than fermentation.
- B** Fermentation requires water and produces the same amount of ATP as aerobic respiration.
- C** Fermentation does not require energy input and produces more ATP than aerobic respiration.
- D** Aerobic respiration breaks down glucose and produces the same amount of ATP as fermentation.

30. Photosynthesis and cellular respiration occur within a plant cell. How are the energy transformations in these two processes related?

- A** Cellular respiration traps solar energy for use in photosynthesis.
- B** Photosynthesis produces glucose that the cell uses for cellular respiration.
- C** Photosynthesis transfers solar energy to cellular respiration for glucose production.
- D** Cellular respiration occurs only during daylight and stores energy to allow photosynthesis to occur at night.

31. Four groups of organic compounds found in living organisms are proteins, carbohydrates, lipids, and nucleic acids. Which element is a main component in nucleic acids but not in the other three organic compounds?

- A carbon
- B oxygen
- C nitrogen
- D phosphorus

32. Collagen is a protein important to reconstructive surgery. Scientists have recently demonstrated the ability to grow human-compatible collagen in genetically modified maize plants. If this technology proves medically useful, it could replace transplants of collagen from natural human-compatible animals. Which is a risk of the maize-derived collagen that does not exist when using animal collagen?

- A** The number of patients requiring collagen transplants could increase as the treatment becomes simpler.
- B** Immune systems of recipients of the collagen could reject the collagen transplants.
- C** Genetically modified maize could spread in the wild and alter the maize gene pool.
- D** The collagen could become infected before transplant into human recipients.

33. The steps of DNA replication are illustrated in the diagram.

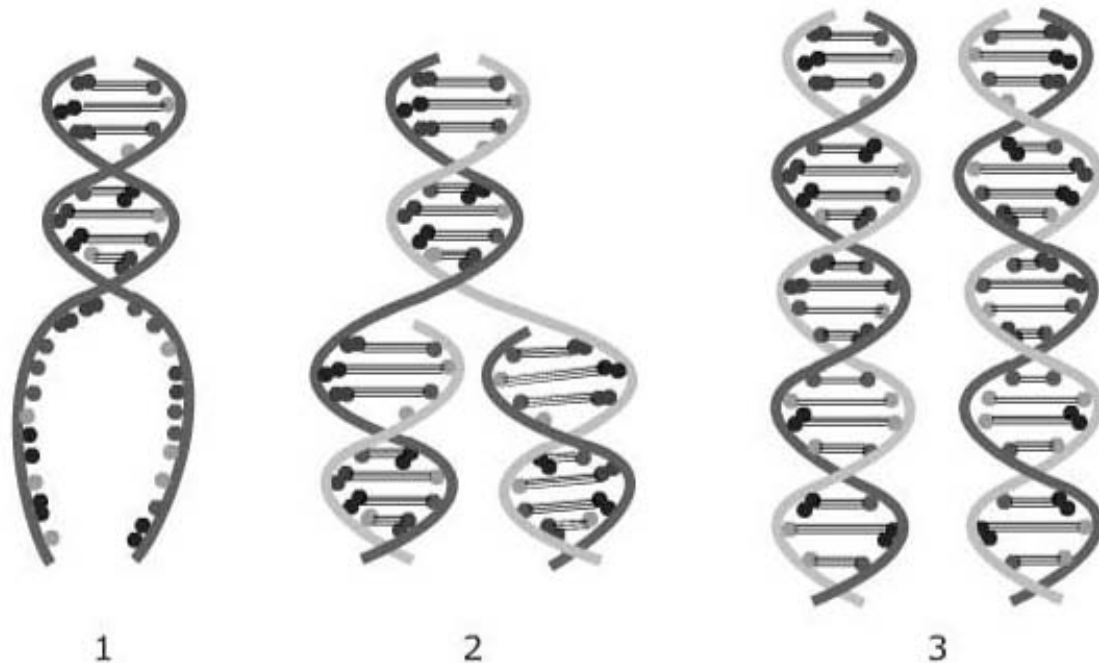

Which statement best describes the purpose of the process of DNA replication?

- A making a new DNA molecule that has different bases
- B producing two exact copies of the cell's original DNA
- C doubling the amount of DNA to increase the number of chromosomes
- D using enzymes to break hydrogen bonds and add nucleotides to strands

34. The process of protein synthesis requires the interaction of many different molecules. Which molecule carries the protein code to a ribosome?

- A** DNA
- B** tRNA
- C** mRNA
- D** rRNA

35.

Molecules and ions are constantly being moved across cell membranes. A student was asked to determine if illustration shows active or passive transport of potassium (K^+) and sodium (Na^+).

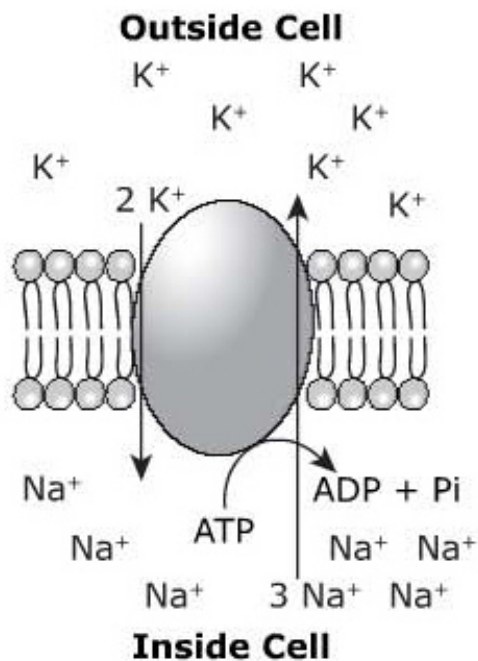

Which statement is the **best** description of the transport occurring in the illustration?

- A Passive transport is occurring only for sodium.
- B Active transport is occurring only for potassium.
- C Active transport is occurring for both potassium and sodium.
- D Passive transport is occurring for both potassium and sodium.

36. Nitrogen, in the form of ammonia, is returned to the soil when plants and animals die. Ammonia then has to be converted to nitrite and nitrate to make it a usable form of ammonia. A decrease of which of these organisms in a soil ecosystem could lead to an increase of ammonia?

- A** bacteria
- B** beetles
- C** snails
- D** worms

37. A woman has a single gene for hemophilia, an X-linked recessive trait. Her husband does not have any genes for hemophilia. What is the probability of their producing a child with hemophilia?

- A** 75%
- B** 50%
- C** 25%
- D** 0%

38. A researcher selects a land area recently formed by volcanic eruption for a study of succession. The measure of which factor will best indicate the progression of biological succession in the land area?

- A mean summer temperature
- B oxygen content of air
- C soil depth
- D water pH

39. A family pedigree is shown. Shaded individuals express a known genetic trait.

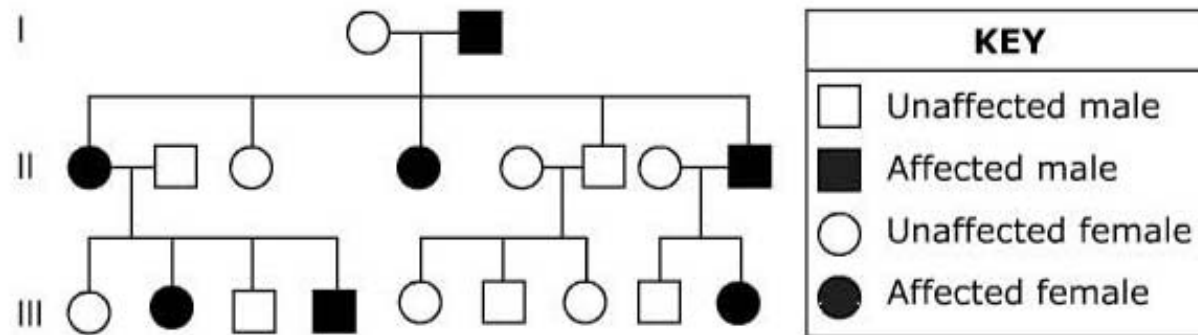

Which is the most likely mode of inheritance of this trait?

- A autosomal dominant
- B autosomal recessive
- C X-linked dominant
- D X-linked recessive

40. Bison feed on grass in a prairie ecosystem. Wolves prey on the bison. How would a drought affect the carrying capacity of bison in this ecosystem?

- A** increase, because fewer wolves would prey on bison
- B** decrease, because more wolves would prey on bison
- C** increase, because bison would have more available food
- D** decrease, because fewer plants would be available as food

41. Meiosis is an important process in sexual reproduction. Which statement best describes the purpose of meiosis in the formation of egg and sperm cells?

- A** Meiosis maintains the cell's original chromosome number.
- B** Meiosis reduces the cell's chromosome number by half.
- C** Meiosis divides the cytoplasm of the egg and sperm.
- D** Meiosis joins the nuclei of the egg and sperm.

42. The illustration shows a simple ecosystem.

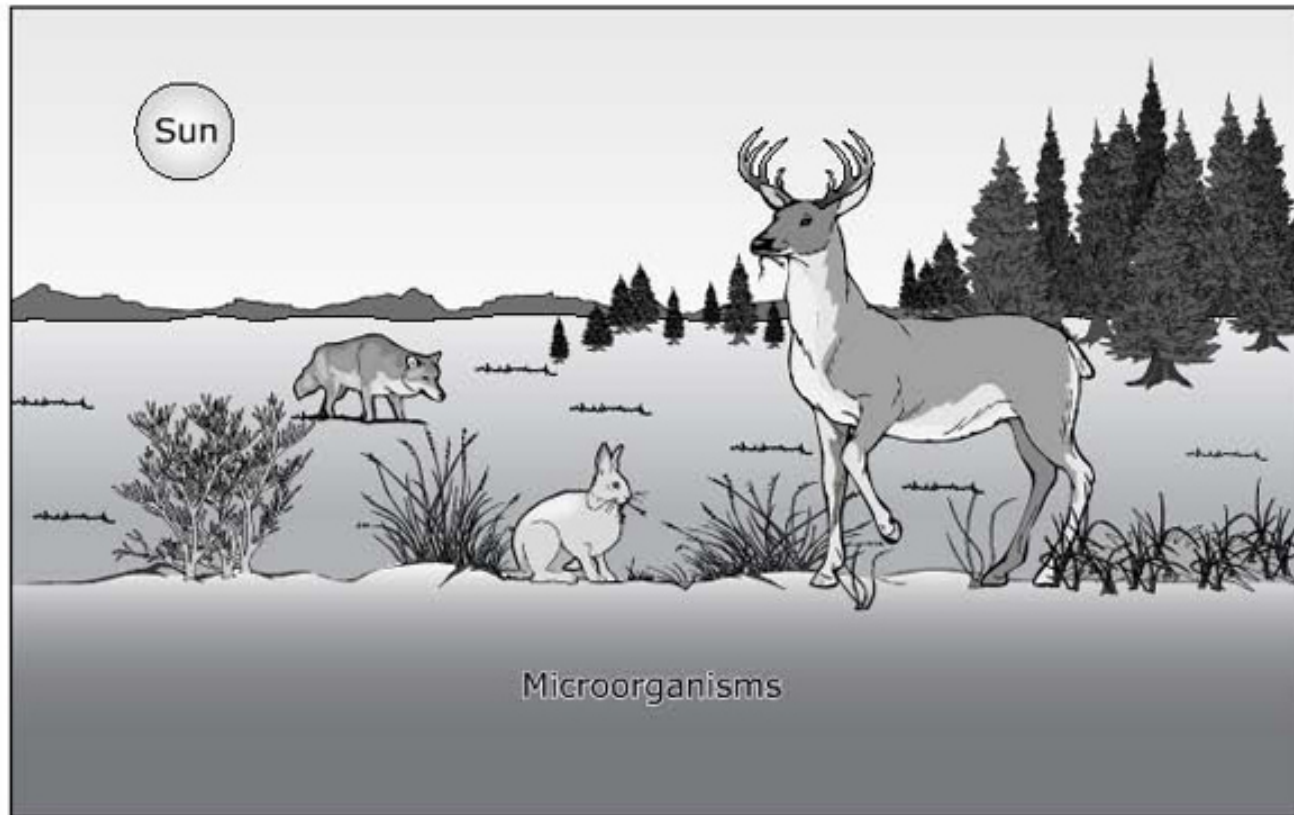

Which two changes in an ecosystem could directly cause a drop in the population size of herbivorous deer?

- A an increase in soil sand content and an increase in average summer temperatures
- B a decrease in soil nutrient content and a decrease in average winter temperatures
- C an increase in decomposer population sizes and an increase in plant population sizes
- D a decrease in plant population sizes and an increase in carnivorous predator population sizes

43. Organisms that reproduce sexually display a high frequency of genetic variation. Which two meiotic processes provide most of the genetic diversity of a species?

- A synapsis and separation
- B replication and condensation
- C polar migration and cytokinesis
- D independent assortment and crossing over

44. The term *cloning* in science can refer to several types of scientific technology, including therapeutic, reproductive, and recombinant DNA. Which result of reproductive cloning poses the greatest ethical issue?

- A offspring that may transmit diseases
- B cells without inherited genetic defects
- C cells that may be used to heal damaged tissues
- D offspring with a heightened risk of developing health problems

45. A student conducted an investigation about the growth of corn seeds. Figure 1 shows corn seeds pinned at different angles on a piece of cardboard and the experimental setup for seed germination. Figure 2 shows the growth of the seeds after 72 hours. The student concluded that the position of the corn seeds had no direct effect on seed growth.

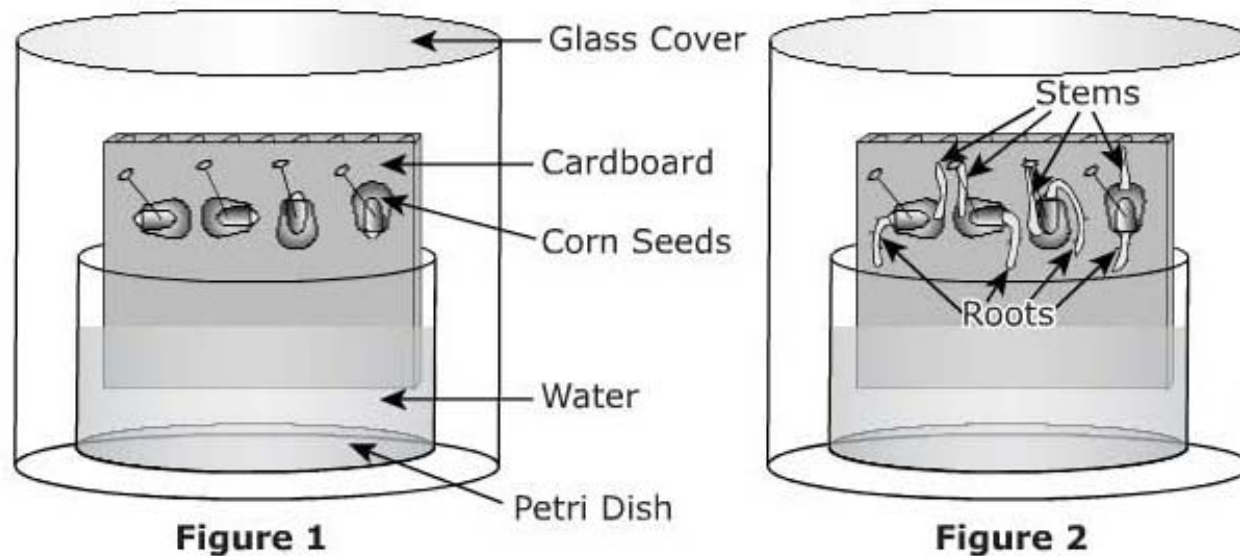

Based on the student's observations, why would this be an acceptable conclusion?

- A The roots and stems are the same lengths.
- B The corn seeds germinated at the same time.
- C The corn seeds are placed in a controlled environment.
- D The roots and stems are growing in the same direction.

46. When muscles work at their maximum ability, blood flow is often unable to provide enough oxygen to continue to produce ATP. Which process allows muscles to continue ATP production in this situation?

- A** beta oxidation
- B** aerobic metabolism
- C** anaerobic metabolism
- D** oxidative phosphorylation

47. Several factors affect the formation of a new species. One example is shown in the diagram.

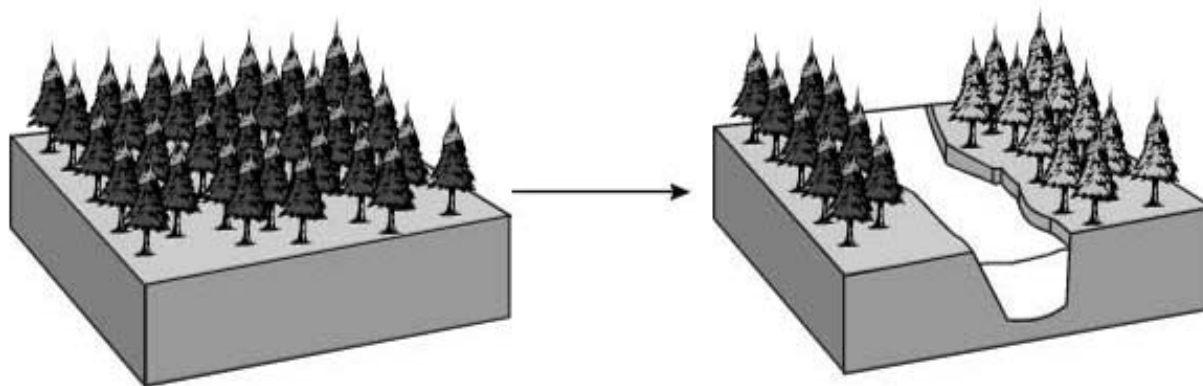

Which **best** explains the formation of the new species of trees in the illustration?

- A A mutation resulted in a change in the chromosome number of some trees.
- B Physical separation prevented gene flow and was followed by genetic change.
- C One group of trees was better suited to the particular environment and survived.
- D Two species of trees formed a fertile hybrid by fertilization which resulted in a new species.

- 48.** A student tests an unknown colorless solution for the presence of lipids, proteins, starches, and sugars. The results are shown in the table.

Reagent	Observation
Benedict's	Colorless to Blue
Biuret	Colorless to Purple
Lugol's	Colorless to Yellowish-Brown
Sudan IV	Colorless to Red

Based on the data in the table, the unknown solution contains which molecules?

- A** sugars and starches
- B** starches and lipids
- C** lipids and proteins
- D** proteins and sugars

49. The Northwest Atlantic loggerhead sea turtles have been listed as threatened under the Endangered Species Act. These sea turtles begin their life on beaches as hatchlings at specific nesting sites along the eastern coastline. The small hatchlings leave their nests at night and go into the ocean using the horizon and water's edge as a guide. They spend several days swimming into the open ocean. There, they drift on currents and feed until they are about the size of a dinner plate. Then, they settle on inshore feeding grounds. They grow slowly and reach sexual maturity between thirty and forty-five years of age. Breeding females return to shallow waters for mating near the beach where they were born. They lay several consecutive clutches of eggs at two weekly intervals. The adults return to sea, and the cycle begins again. How could artificial lighting contribute to the loss of the Northwest Atlantic loggerhead population?

- A** confuse hatchlings about direction as they go into the ocean
- B** confuse males about location of original breeding area
- C** increase the visibility of adult turtles to their predators
- D** increase the rate at which turtles reach sexual maturity

50. Many scientists think that the mitochondria in eukaryotic cells originated as independent prokaryotes. Which characteristic of mitochondria most strongly supports this conclusion?

- A** They are smaller than the cells that contain them.
- B** They are able to transform sunlight into chemical energy.
- C** They lack membrane-bound organelles but include their own DNA.
- D** They are able to release chemical energy from energy-storage molecules.

- 51.** A scientist has identified the gene sequence 5'-ATG GGT GAT GTT GAA AAA-3' in a species. The gene sequence is compared with other species to check for relatedness. The species sequences are shown in the table.

Species	Gene Sequence
1	5'-ATC GGT GAT GTT GAA ATA-3'
2	5'-ATG GGT GAA GTT GTT AAA-3'
3	5'-ATG GGT GAA GTT GAA AAA-3'
4	5'-ATG GGC GAT GTT GAA TTT-3'

Based on the gene sequence from the four species, which species sequence is most closely related to the sequence identified by the scientist?

- A species 1
- B species 2
- C species 3
- D species 4

53. Which process necessary for cell reproduction occurs during cell growth?

- A** DNA replication
- B** RNA replication
- C** dissolution of the cell membrane
- D** dissolution of the nuclear membrane

54. A student uses Biuret solution to test a 1-gram sample of an organic macromolecule. The solution turns purple. What can the student conclude about the function of the macromolecule in a living organism?

- A The macromolecule encodes information.
- B The macromolecule stores energy for short periods.
- C The macromolecule stores energy for long periods.
- D The macromolecule helps cells perform actions or maintain structure.

55. A food pyramid is shown.

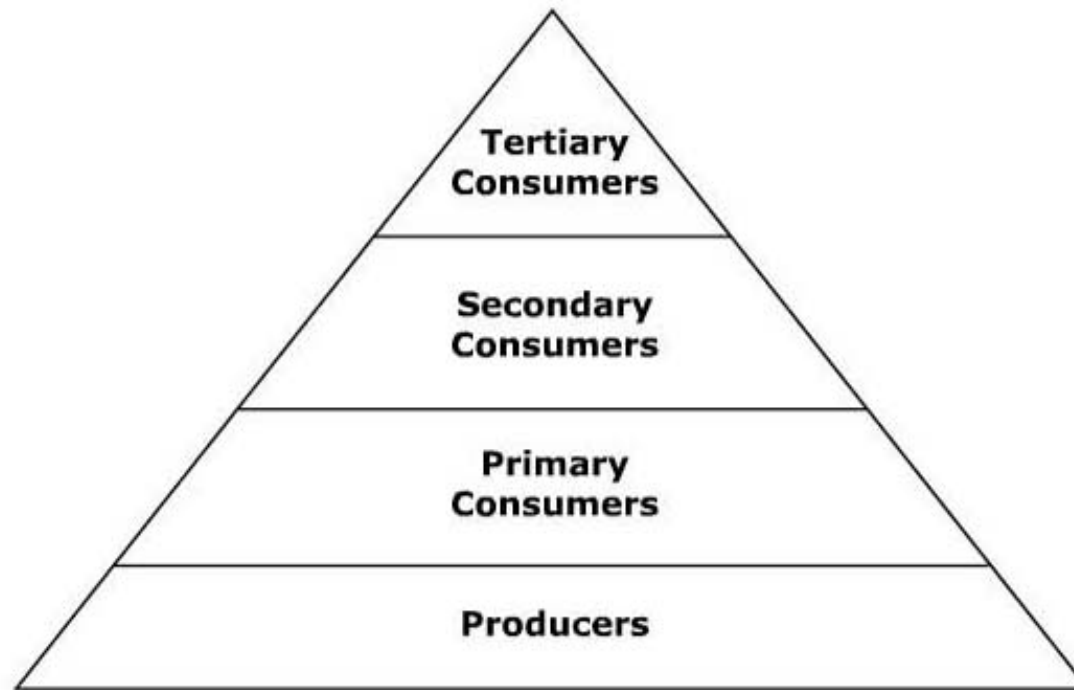

How does the amount of energy change at different levels in the food pyramid?

- A** Producers have the least amount of net energy.
- B** Tertiary consumers have the greatest amount of net energy.
- C** Energy flows from secondary consumers to primary consumers.
- D** Energy is lost in the flow from primary consumers to secondary consumers.

56. Researchers in a biomedical company identify that an artificial knee currently being used has to be replaced in 8-10 years. The researchers proceed development of an artificial knee using the following process:

- **Brainstorm possible solutions**
- **Generate ideas**
- **Explore possibilities**
- **Select an approach**
- **Refine the design**
- **Market the product**

Which step in the design process did the researchers neglect to perform?

- A** Design a prototype knee.
- B** Compare the design to other artificial knees used in the market.
- C** Apply for federal approval for use of the artificial knee.
- D** Evaluate the ability of the artificial knee to perform properly.

57. Which body covering is best suited for a dry, rocky environment?

- A** colorful feathers
- B** moist skin
- C** scaly skin
- D** thick fur

58. The cell membrane regulates the movement of molecules in and out of the cell. Which best describes the cellular environment that initiates the passive transport of molecules across a cell membrane?

- A** a concentration gradient across the cell membrane
- B** a concentration gradient that is equal on both sides of the cell membrane
- C** the availability of ATP to move molecules against the concentration gradient
- D** the availability of proteins to direct the movement of molecules against the concentration gradient

59. The ability of an ecosystem to support life declines sharply after a population crash among some of the organisms. A population crash among organisms with which characteristic could have caused the sharpest decline?

- A** hibernation during the winter
- B** mobility on land and in the air
- C** conversion of sunlight into food energy
- D** different fur coloring in summer and winter

60. During the process of photosynthesis, light energy is used to synthesize glucose molecules. Which product from this process is used to convert the glucose to energy during cellular respiration?

- A** water
- B** oxygen
- C** nitrogen
- D** carbon dioxide

61. The sequence of bases in an RNA strand is determined by the complementary base pairings with a DNA strand. Which base pairs with adenine on the DNA strand during transcription?

- A thymine
- B uracil
- C guanine
- D cytosine

62. As a cell grows in size, transport of materials in and out of the cell becomes more difficult. Which event helps a cell to efficiently transport material as the cell grows?

- A** The cell undergoes mitosis.
- B** The cell undergoes mutation.
- C** The cell develops a thicker cell wall.
- D** The cell stores more materials in its vacuoles.

- 63.** The genetic disorder associated with a mutation in chromosome 5 results in children who make catlike cries and have various levels of mental and physical impairments. A pair of chromosome 5 from a karyotype and a nonmutated chromosome 5 are shown.



The genetic disorder is likely caused by which type of mutation?

- A translocation
- B nondisjunction
- C insertion
- D deletion

64. Catalase is a class of enzyme which acts on the decomposition reaction of hydrogen peroxide:



How does catalase alter this reaction?

- A** Catalase decreases the mass of product per unit reactant.
- B** Catalase increases the mass of product per unit reactant.
- C** Catalase slows down the reaction.
- D** Catalase speeds up the reaction.

65.

The food web below shows the relationships between organisms in a boreal forest biome. Snowshoe hare populations rise and fall in different years. Most other small herbivores hibernate through the winter. This affects the winter food supply for predators.

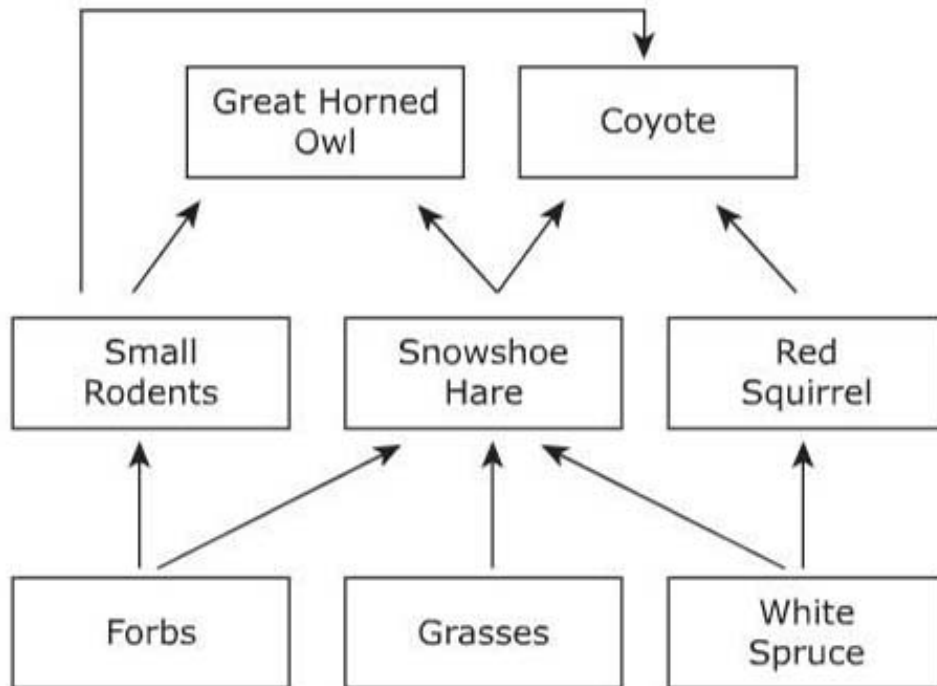

What factor in this ecosystem allows coyotes to survive in years with low snowshoe hare populations?

- A productivity of producers
- B specialization of predators
- C diversity of primary consumers
- D open niches for secondary consumers

**Biology I Form 1
Answer Key**

Item Number	Correct Answer
1	D
2	A
3	A
4	C
5	B
6	C
7	C
8	C
9	C
10	D
11	B
12	C
13	A
14	C
15	C
16	B
17	D
18	B
19	D
20	C
21	B
22	D

Item Number	Correct Answer
23	A
24	C
25	B
26	D
27	A
28	B
29	A
30	B
31	D
32	C
33	B
34	C
35	C
36	A
37	C
38	C
39	A
40	D
41	B
42	D
43	D
44	D

Item Number	Correct Answer
45	D
46	C
47	B
48	C
49	A
50	C
51	C
52	A
53	A
54	D
55	D
56	A
57	C
58	A
59	C
60	B
61	B
62	A
63	D
64	D
65	C

Reporting Categories

Below you will find that each item has been linked to its corresponding Reporting Category. These five Reporting Categories will be used to report scores from the actual test.

You can find the Reporting Categories and their Performance Indicators grouped together in the Tennessee End of Course Item Sampler for Biology I located on the Tennessee Department of Education Web site at http://tennessee.gov/education/assessment/sec_samplers.shtml.

Item	Reporting Category
1	5 -Heredity
2	4 -Flow of Matter & Energy
3	2 -Cells
4	5 -Heredity
5	2 -Cells
6	4 -Flow of Matter & Energy
7	1 –Inquiry, Technology & Engineering, Mathematics
8	5 -Heredity
9	6 –Biodiversity & Change
10	1 –Inquiry, Technology & Engineering, Mathematics
11	1 –Inquiry, Technology & Engineering, Mathematics
12	2 -Cells
13	2 -Cells
14	1 –Inquiry, Technology & Engineering, Mathematics
15	4 -Flow of Matter & Energy
16	2 -Cells
17	2 -Cells
18	5 -Heredity
19	6 –Biodiversity & Change
20	2 -Cells
21	3 -Interdependence
22	1 –Inquiry, Technology & Engineering, Mathematics

Item	Reporting Category
23	1 –Inquiry, Technology & Engineering, Mathematics
24	2 -Cells
25	5 -Heredity
26	3 -Interdependence
27	3 -Interdependence
28	4 -Flow of Matter & Energy
29	4 -Flow of Matter & Energy
30	4 -Flow of Matter & Energy
31	2 -Cells
32	1 –Inquiry, Technology & Engineering, Mathematics
33	5 -Heredity
34	5 -Heredity
35	2 -Cells
36	4 -Flow of Matter & Energy
37	5 -Heredity
38	3 -Interdependence
39	5 -Heredity
40	3 -Interdependence
41	5 -Heredity
42	3 -Interdependence
43	5 -Heredity
44	5 -Heredity
45	1 –Inquiry, Technology & Engineering, Mathematics
46	4 -Flow of Matter & Energy
47	6 –Biodiversity & Change
48	2 -Cells
49	3 -Interdependence
50	2 -Cells
51	6 –Biodiversity & Change
52	6 –Biodiversity & Change
53	2 -Cells

Item	Reporting Category
54	2 -Cells
55	4 -Flow of Matter & Energy
56	1 -Inquiry, Technology & Engineering, Mathematics
57	6 -Biodiversity & Change
58	2 -Cells
59	3 -Interdependence
60	4 -Flow of Matter & Energy
61	5 -Heredity
62	2 -Cells
63	5 -Heredity
64	2 -Cells
65	6 -Biodiversity & Change